

250 PSI WWP Iron Body Gate Valves

Fire Protection Post Indicator Valve • Bolted Bonnet • Indicator Post Pattern • Non-Rising Stem
• Resilient Wedge • Epoxy Coated Interior/Exterior

250 PSI/17.2 Bar Non-Shock Cold Working Pressure
(160° F/71° C max. operating temperature)

UL/ULC LISTED • FM APPROVED • AWWA C-509 & 515 •
NEW YORK CITY M.E.A. APPROVED 236-93E •
CERTIFIED LEAD-FREE* BY IAPMO R&T TO NSF/ANSI 372

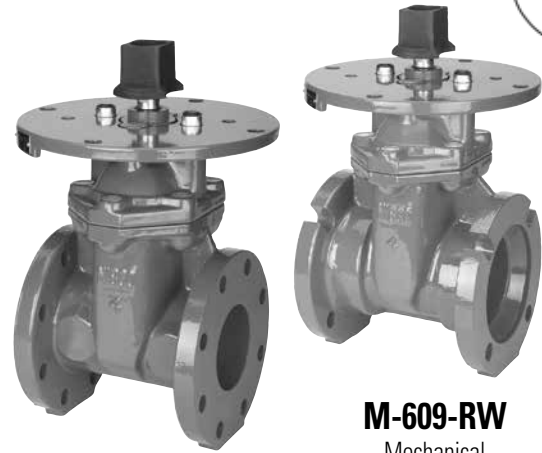

M-609-RW
Mechanical

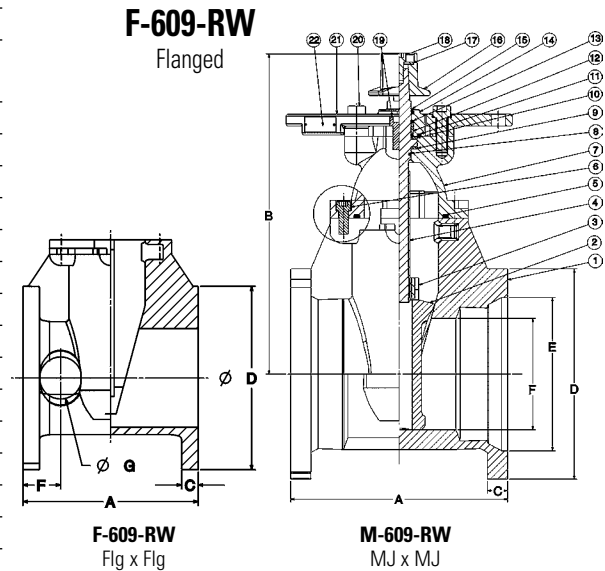

F-609-RW
Flanged

F-609-RW
Flg x Flg

M-609-RW
MJ x MJ

MATERIAL LIST

PART	SPECIFICATION
1. Valve Body	Ductile Iron ASTM A536
2. Resilient Wedge	Ductile Iron ASTM A536/EPDM ASTM D2000
3. Wedge Nut	Bronze ASTM B584 UNS C83600
4. Stem	Bronze ASTM B150 UNS C61400
5. Bonnet Gasket	EPDM ASTM D2000
6. Bonnet Screw	(F) Alloy Steel ASTM A574M Zinc Plated (M) 18-8 Stainless Steel ASTM 193
7. Bonnet	Ductile Iron ASTM A536
8. Stem Primary O-Ring	EPDM ASTM D2000
9. Stem Thrust Washer (lower)	Bronze ASTM B584 UNS C83600
10. Stem Thrust Washer (upper)	Stainless Steel ASTM A276 UNS S41000
11. Gland Seal O-Ring	EPDM ASTM D2000
12. Stem Seal Bushing	Bronze ASTM B584 UNS C83600
13. Stem Secondary O-Ring	EPDM ASTM D2000
14. Gland Flange	Ductile Iron ASTM A536
15. Stem Ring Wiper	EPDM ASTM D2000
16. Square Operating Nut	Cast Iron ASTM A126 Class B
17. Operating Nut Washer	Carbon Steel Zinc Plated
18. Operating Nut Screw	Alloy Steel ASTM A574M Zinc Plated
19. Gland Flange Screw	Alloy Steel ASTM A574M Zinc Plated
20. Indicator Flange Screw	Alloy Steel ASTM A574M Zinc Plated
21. Indicator Post Flange	Ductile Iron ASTM A536
22. UL/FM Label	Aluminum

NOTE: Body, Bonnet and Ind. Post Flange coated with electrostatically applied fusion bonded epoxy resin inside and outside per AWWA C-550. Epoxy NSF and FDA certification

NOTE: Flanged valve is consistent with ANSI B16.1 Class 125.

DIMENSIONS—WEIGHTS—QUANTITIES

M-609-RW Dimensions													Bolt				
Size	A		B		C		D		E		F		Circle	Flange	Turns	Weight	
In. mm.	In. mm.	In. mm.	In. mm.	In. mm.	In. mm.	In. mm.	In. mm.	In. mm.	In. mm.	In. mm.	In. mm.	In. mm.	In. mm.	Holes	To Open	Lbs.	Kg.
4 100	10.0 254	13.5 344	1.00 26	9.1 232	6.0 153	3.9 100	7.50 191	4	13.0	89	40						
6 150	11.5 292	17.4 441	1.06 27	11.1 283	8.1 206	5.9 150	9.50 241	6	15.7	132	60						
8 200	11.5 292	20.8 529	1.12 28	13.4 340	10.3 261	7.9 200	11.75 298	6	17.3	190	86						
10 250	13.0 330	24.2 614	1.18 30	15.7 400	12.3 313	9.8 250	14.00 356	8	21.4	287	130						
12 300	14.0 356	27.6 700	1.25 32	18.0 456	14.4 367	11.8 300	16.25 413	8	25.3	408	185						

F-609-RW Dimensions													Bolt				
Size	A		B		C		D		F		G		Circle	Flange	Turns	Weight	
In. mm.	In. mm.	In. mm.	In. mm.	In. mm.	In. mm.	In. mm.	In. mm.	In. mm.	In. mm.	In. mm.	In. mm.	In. mm.	In. mm.	Holes	To Open	Lbs.	Kg.
4 100	9.0 229	13.5 344	0.94 24.0	9.0 229	2.13 54	2.1 54	7.50 191	8	13.0	91	41						
6 150	10.5 267	17.4 441	1.00 25.4	11.0 279	2.24 57	2.5 64	9.50 241	8	15.6	142	65						
8 200	11.5 292	20.8 529	1.13 28.6	13.5 343	2.48 63	2.8 70	11.75 298	8	17.3	216	98						
10 250	13.0 330	24.2 614	1.19 30.2	16.0 406	2.56 65	2.8 70	14.25 362	12	21.4	314	143						
12 300	14.0 356	27.6 700	1.25 31.8	19.0 483	2.91 74	3.4 86	17.00 432	12	25.3	446	203						



FREEZING WEATHER PRECAUTION: Subsequent to testing a piping system, gate valve should be in an open position to allow complete drainage.

*Lead Free refers to the wetted surface of pipe, fittings and fixtures in potable water systems that have a weighted average lead content ≤ 0.25% per the Safe Drinking Water Act (Sec. 1417) amended 1-4-2011 and other equivalent state regulations.